



Circular pumps BFP ATEX-3GD

Drives and hydraulic aggregates with bypass filter and/or cooler are also used in explosive areas in machine construction or raw material production. The advantage of these circuits is that they create stable and therefore more predictable operating conditions for both the filtration and cooling.

Circulating oil in these circuits requires efficient and preferably silent circulation pumps which provide a constant flow rate at moderate pressures.

Internal gear pumps have proved especially useful for these applications. They offer compact integration, are relatively insensitive to particle contamination and have a long life.

BFP ATEX 3GD series gerotor motor/pump units are particularly suitable for use in explosive zones 2 (gas) and 22 (dust) and temperature class 3.

ATEX area of application: up to zone 2 and zone 22 T3

Low noise emission

High vol. efficiency

Good suction performance

Gerotor principle

Not susceptible to contamination



Introduction and description

Why gerotor?

Numerous applications in hydraulic and lubrication systems just require the circulation of the fluid. In such cases low noise emissions and low pressure ripples are more important than highly efficient transmission of energy.

The gerotor is the ideal principle for such applications. The displacement mechanism consists of the inner and the outer rotor. The number of teeth of the inner rotor is always one less than the outer rotor. The rotation of the gerotor generates chambers of changing volumes between the inner and outer rotor. The variation follow a sinus curve, resulting in a very steady surge. Due to the inevitable displacement, the flow rate generated is proportional to the rotation speed.

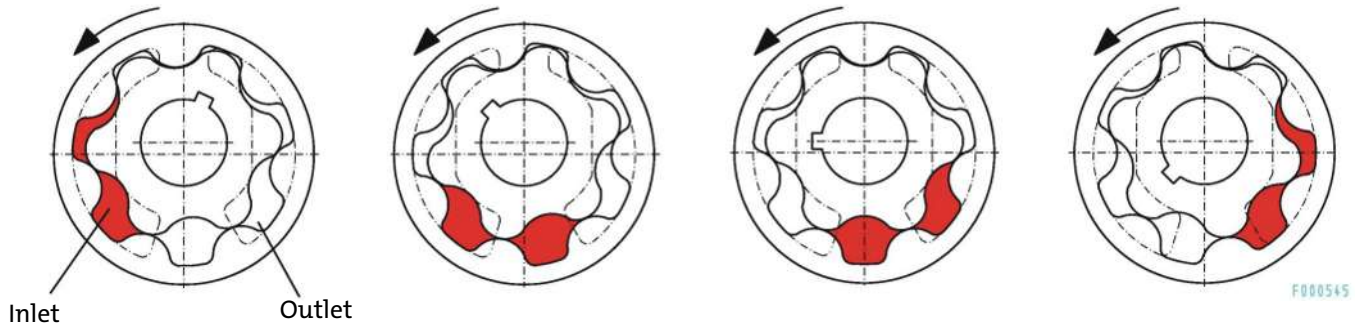

When we designed the BFP series we specifically selected the number of teeth and the width of the gerotors so the pumps have the smallest possible physical dimensions, low weight and minimal loss in efficiency. The low relative speed between the internal and external gear make the pumps extremely durable and smooth.

The internal design of the pumps further reduces the flow paths and ensures good suction performance.

Why complete pump units?

Every additional component increases the overall installed size of the systems, inevitably increasing the space requirement and typically also the costs. One requirement in developing the BFP series was therefore to keep them as short and compact as possible. On the BFP 8 to 40 models the gerotor is driven directly by the motor shaft. On the larger BFP 60 and 90 pumps the motor shaft is built into a special coupling. The coupling runs in oil and is therefore optimally lubricated and cooled.

ATEX mark

ATEX marking on standard equipment

The ATEX mark depends on the version of the equipment and provides information on equipment category, equipment group, ex-atmosphere, ignition protection type. Please refer to the chart below for possible and complete markings.

Version for	Marking	Explanation
Gas	II 3G Ex h IIC T3 Gc	Zone 2 (IIC hydrogen only) Temperature class T3
Dust	II 3D Ex h IIIB T125 °C Dc	Zone 22 max. surface temperature 125 °C

Gas and dust atmosphere must not be present at the same time.

Pump selection information:

When selecting the pump model, choose the motor output according to the oil viscosity to be used. Motor output information refers to the maximum oil viscosity at maximum operating pressure.

The BFP 8 to BFP 40 are also available as a special version with a 6 bar internal bypass valve for protection. This does not change the dimensions.

Installation information:

The pump head of all pumps can be mounted turned in 90° increments to align with the line routing. Please note the offset from the centre of the motor.

The connection threads are manufactured to ISO 228. The screw-in surfaces are finished and suitable for the use of soft seals. We recommend using screwed plugs per ISO 1179-2.

Please note:

Especially note the dimension of the suction pipe. The cross-sections should not be smaller than specified. In most cases, loud noise indicates the cross-section was reduced too much.

Please refer to the notices in the operating instructions.

BFP 8 / BFP 15

	BFP 8-4-0.75 kW	BFP 15-4-0.75 kW	BFP 15-4-1.5 kW
Item number	3708075ATEX3GDT3	3715075ATEX3GDT3	3715150ATEX3GDT3
Motor power	0.75 kW	0.75 kW	1.5 kW
Max. oil viscosity	1500 cSt	300 cSt	2000 cSt
At max. operating pressure	8 bar		
Number of poles	4		
Max. power input (400 V/50 Hz)	approx. 1.65 A	approx. 1.65 A	approx. 3.35 A
Nominal delivery volume at 50/60 Hz	5.8 cm ³ /U	11.7 cm ³ /U	11.7 cm ³ /U
	8/10 L/min	16/20 L/min	16/20 L/min
Suction side connection	G3/4 – DN20	G1 1/4 – DN32	G1 1/4 – DN32
Pressure side connection	G1/2 – DN16	G1 – DN25	G1 – DN25
Suction pressure for all types briefly up to	-0.4 bar		
	-0.6 bar		
Acoustic power per ISO 3744	56 dB(A)	59 dB(A)	59 dB(A)
Weight	18.5 kg	18.1 kg	23.6 kg
Dimensions			
A	96.5	96.5	100
B	324	324	376
C	96	96	120
D	82	70	70
E	71	60	60
F	80	80	90
G	218	218	236
H	125	125	140
J	152	152	177
K	77	77	87
L	100	100	125
M	4xØ10	4xØ10	4xØ10

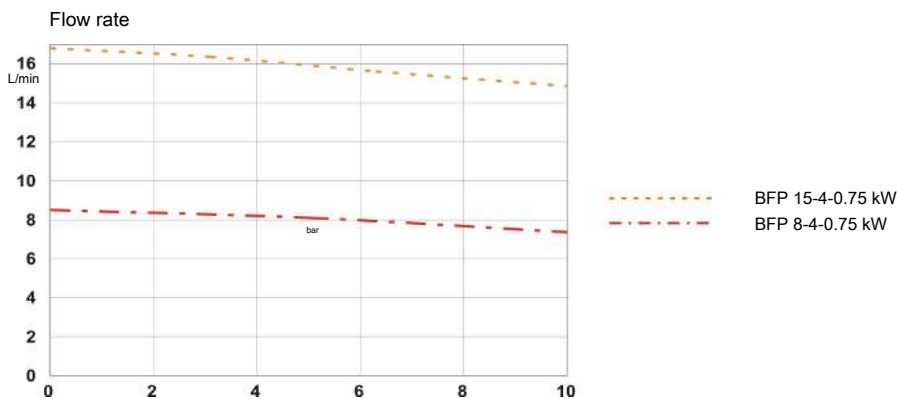
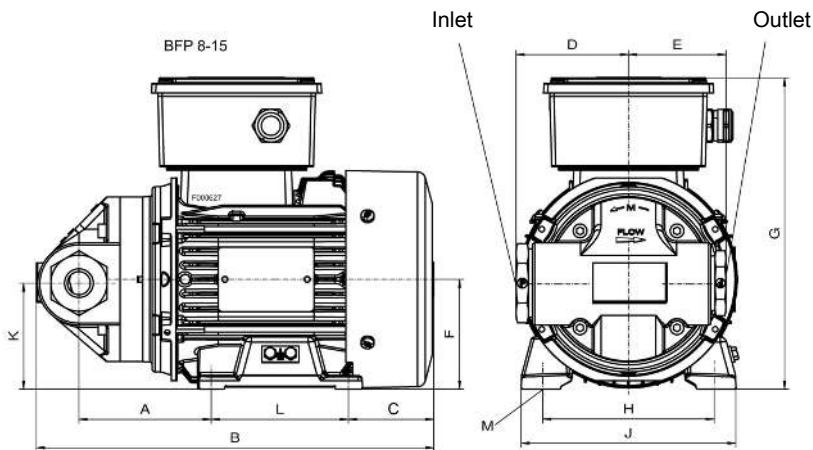

BFP 30 / BFP 40

	BFP 30-4-0.75 kW	BFP 30-4-1.5 kW	BFP 40-4-1.5 kW
Item number	3730075ATEX3GDT3	3730150ATEX3GDT3	3740150ATEX3GDT3
Motor power	0.75 kW	1.5 kW	1.5 kW
Max. oil viscosity	100 cSt	1000 cSt	700 cSt
At max. operating pressure	6 bar	8 bar	6 bar
Number of poles	4		
Max. power input (400 V/50 Hz)	approx. 1.65 A	approx. 3.35 A	approx. 3.35 A
Nominal delivery volume at 50/60 Hz	20.4 cm ³ /U 29/35 L/min	20.4 cm ³ /U 29/35 L/min	30.6 cm ³ /U 42/50 L/min
Suction side connection	G1 1/4– DN32		
Pressure side connection	G1 – DN25		
Suction pressure for all types briefly up to	-0.4 bar -0.6 bar		
Acoustic power per ISO 3744	61 dB(A)	61 dB(A)	62 dB(A)
Weight	18.8 kg	24.3 kg	24.8 kg
Dimensions			
A	95	98.5	108
B	323	375	384
C	96	120	120
D	80	90	90
E	218	236	236
F	125	140	140
G	152	177	177
H	77	87	87
J	100	125	125
K	4xØ10	4xØ10	4xØ10

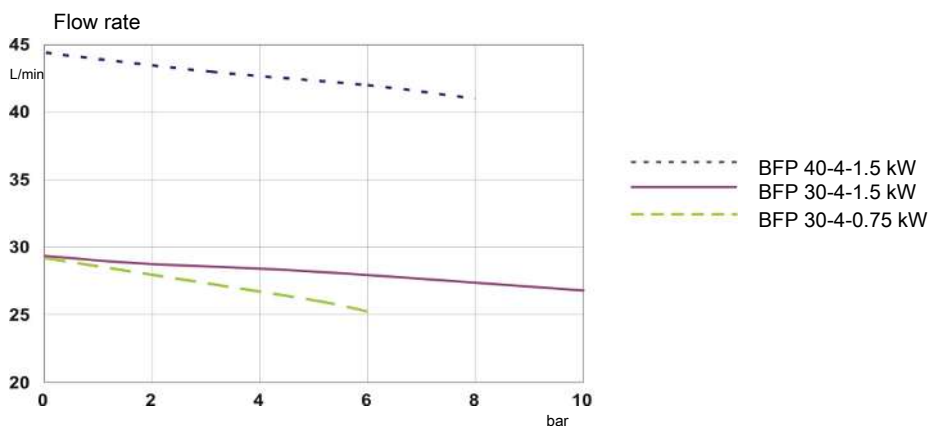
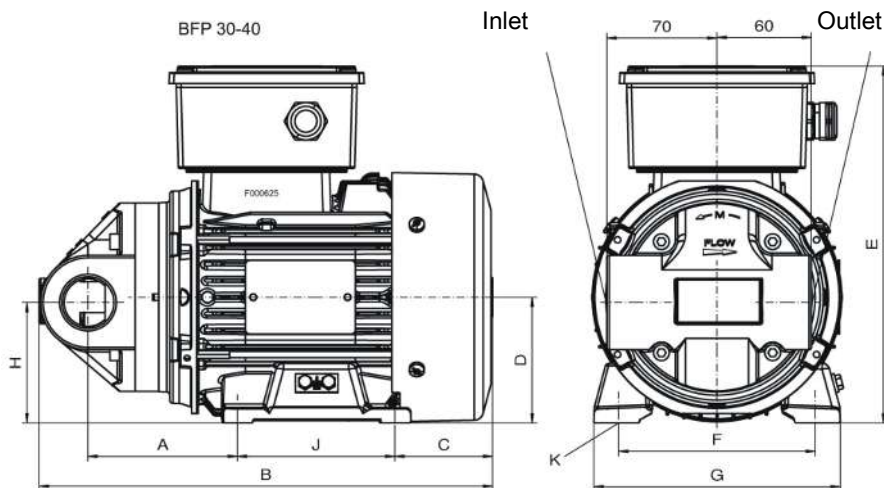

BFP 60

	BFP 60-4-2.2 kW	BFP 60-4-3 kW
Item number	3760220ATEX3GDT3	3760300ATEX3GDT3
Motor power	2.2 kW	3 kW
Max. oil viscosity	300 cSt	900 cSt
At max. operating pressure	8 bar	
Number of poles	4	
Max. power input (400 V/50 Hz)	approx. 4.8 A	approx. 6.5 A
Nominal delivery volume at 50/60 Hz	40.8 cm ³ /U	
	58/70 L/min	
Suction side connection	G1 1/2– DN40	
Pressure side connection	G1 1/4– DN32	
Suction pressure for all types briefly up to	-0.4 bar	
	-0.6 bar	
Acoustic power per ISO 3744	64 dB(A)	
Weight	40.3 kg	49.3 kg
Dimensions		
A	172	172
B	471	501
C	128	158
D	140	140
E	97	97
F	100	100
G	160	160
H	193	193
J	255	255
K	4xØ12	4xØ12

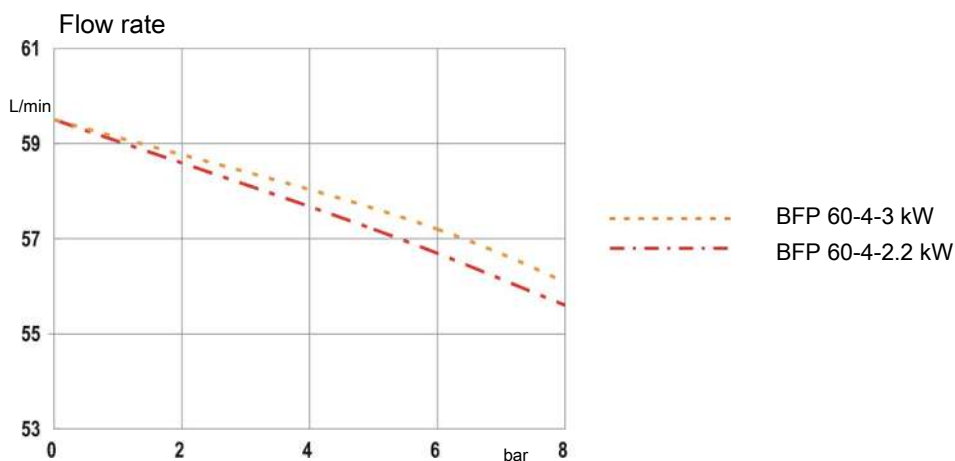
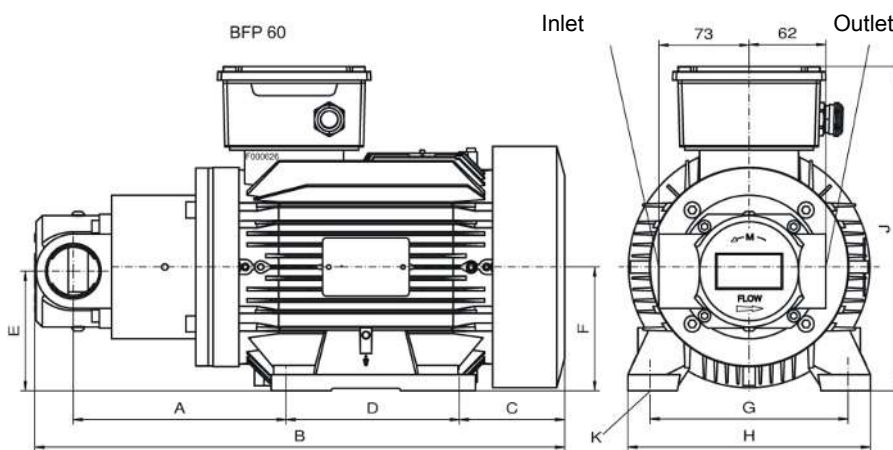

BFP 90

	BFP 90-4-2.2 kW	BFP 90-4-3 kW
Item number	3790220ATEX3GDT3	3790300 ATEX3GDT3
Motor power	2.2 kW	3 kW
Max. oil viscosity	100 cSt	300 cSt
At max. operating pressure	8 bar	
Number of poles	4	
Max. power input (400 V/50 Hz)	approx. 4.8 A	approx. 6.5 A
Nominal delivery volume at 50/60 Hz	61.2 cm ³ /U	
	88/105 L/min	
Suction side connection	G1 1/2– DN40	
Pressure side connection	G1 1/4– DN32	
Suction pressure for all types briefly up to	-0.4 bar	
	-0.6 bar	
Acoustic power per ISO 3744	65 dB(A)	
Weight	41.3 kg	50.3 kg
Dimensions		
A	184.5	184.5
B	505	535
C	128	158
D	140	140
E	97	97
F	100	100
G	160	160
H	193	193
J	255	255
K	4xØ12	4xØ12

