



Oil/air cooler BLK ATEX-3GD

Drives and hydraulic aggregates are also used in explosive areas in machine construction or raw material production.

In hydraulic systems oil transfers power and motion, in drives it's a vital lubricant. Both as a power transfer medium and lubricant oil is heated by friction losses during operation. Oil/air coolers stabilise the temperature and are indispensable for systems and drives for consistent power. The temperature further affects the ageing behaviour and the life of oils.

BLK ATEX 3GD series coolers are suitable for use in zones 2 (gas) and 22 (dust) and temperature class 3. In addition to adequately protected drive motors they have stainless steel fan housings.

Efficient cooling matrixes, an easy to maintain design and noise-optimised fans are additional features of the BLK ATEX series.

ATEX area of application: up to zone 2 and zone 22 T3

Easy to maintain design

Compact installation dimensions

Low noise emission

Broad performance range

Rugged cooling matrix



Introduction and description

Why coolers?

There are basically two main concepts in the development of fluid power systems.

One is to design systems without using a cooler, and if operational conditions show that the system needs a cooler, install it later at additional costs. This understandably then often calls for compromises, making the system more expensive.

The other concept recognizes that a system originally designed with an integrated cooler needs less installation space and is a better choice with respect to construction and system costs.

Why Bühler?

If an oil/air cooler is planned for cooling it needs to have a simple and compact design, noise emission be low, and be easy and quick to maintain.

When we developed the BLK series, we incorporated our years of experience in designing and selling oil/air coolers. Especially the fatigue life of the cooling matrix was a focus during development, since in some cases the matrix has to withstand considerable pressure peaks in the return line.

The cooling matrix can easily be removed from the fan case for maintenance without uninstalling the fan or motor.

If our comprehensive standard range of products does not include the right solution for your application, we will gladly develop a custom solution for you.

Use the data in this leaflet to determine a suitable cooler for your application.

Construction and application

The BLK series consist of the following components:

- Cooling matrix
- Fan case with mounting rails
- Blower, consisting of AC motor, fan and protective/mounting grate
- The cooling matrix and fan can be removed from the fan case individually without having to uninstall other components

The BLK series cooling matrix are made from aluminum. The coolers are designed for use in hydraulic circuits - including return lines. They are not suitable for pure water.

We also offer cooling matrixes with bypass (see type code).

Depending on the application or system requirements, off line filtration is often required. In these cases we recommend combining them with an off line circuit. You will find suitable units in our BNK series. These units are also suitable for upgrading existing systems.

ATEX mark

ATEX marking on standard equipment

The ATEX mark depends on the version of the equipment and provides information on equipment category, equipment group, ex-atmosphere, ignition protection type. Please refer to the chart below for possible and complete markings.

Version for	Marking	Explanation
Gas	II 3G Ex h IIC T3 Gc	Zone 2 (IIC hydrogen only) Temperature class T3
Dust	II 3D Ex h IIIB T125 °C Dc	Zone 22 max. surface temperature 125 °C

Gas and dust atmosphere must not be present at the same time.

Ignition protection mark explanation

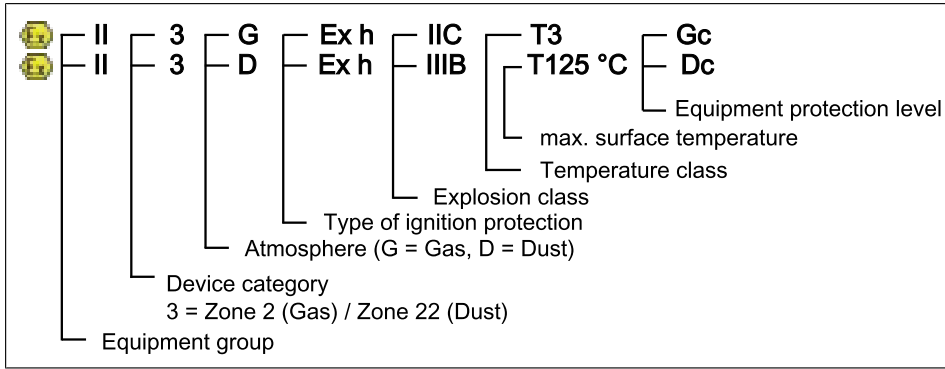

Model key

BLK 4.4-ATEX-3GDT3-IBx

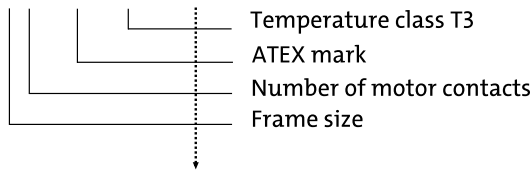

BLK 4.4-ATEX-3GDT3-IBx *If a bypass is desired, the information is added to the to the type designation:*

Bypass version	AB	(BLK 2-8)	external bypass
	IBx	(BLK 3-8)	internal bypass
	ITB	(BLK 3-8)	internal temperature-dependent bypass 2 bar / 45 °C
	ATB	(BLK 2-8)	external temperature-dependent bypass 2 bar / 45 °C
	x		bypass value 2 bar, 5 bar, 8 bar

Technical data

Technical Data

Cooling battery:	Aluminium, RAL 7001, painted
Ventilation box, safety guard and motor brackets:	Stainless steel 1.4401, unpainted
Fan hub:	Aluminium die casting
Motor housing:	Aluminium die casting
Motor flanges:	Grey cast iron
Operating fluids:	Mineral oils per DIN 51524 Gear oil per DIN 51517-3 Oil/water emulsions HFA and HFB per CETOP RP 77 H Water glycol HFC per CETOP RF 77 H Phosphoric ester HFD-R per CETOP RP 77 H
Operating pressure static:	max. 21 bar
dynamic:	15 bar (at 5 MM load cycle, 3 Hz)
Operating oil temperature:	max. 100 °C
max. viscosity:	100 cSt medium viscosity (see viscosity charts), higher upon request
Ambient temperature:	-15 to 40 °C (higher temperatures up to 60 °C upon request)

Electric motors (others available upon request)

Voltage / frequency:	230 / 400 V - 50 Hz ± 5 % 277 / 480 V - 60 Hz ± 5 %
Thermal stability:	Class of insulation F, utilisation per class B
Colour:	RAL 7031
Protection class:	IP 55

The motors comply with standards IEC 60034, IEC 60072, IEC 60085

Please also observe the operating manual for the motor!

Basic data BLK ATEX-3GDT3 (at a frequency of 50 Hz)

Part no.*	Cooler type	Power output Poles Rated current at 400 V	Weight (kg)	Capacity (l)	Noise emission dB(A)**
3502400ATEX3GDT3	BLK 2.4	0.25 kW / 4 / 0.8 A	23	1.3	66
3503400ATEX3GDT3	BLK 3.4	0.25 kW / 4 / 0.8 A	28	1.8	71
3504400ATEX3GDT3	BLK 4.4	0.37 kW / 4 / 1.1 A	34	2.3	73
3505410ATEX3GDT3	BLK 5.4	0.75 kW / 4 / 1.7 A	57	3.1	79
3506410ATEX3GDT3	BLK 6.4	2.2 kW / 4 / 4.8 A	94	4.1	86
3507410ATEX3GDT3	BLK 7.4	2.2 kW / 4 / 4.8 A	104	5.4	89
3508610ATEX3GDT3	BLK 8.6	1.5 kW / 6 / 3.45 A	125	6.3	79

*Cooler models BLK2.4 bis BLK 4.4 operate at 50/60 Hz, BLK 5.4 to BLK 8.6 at 50 Hz (60 Hz models upon request).

**DIN EN ISO 3744, Class 3

Calculation example and nomenclature
Determination

An oil/air cooler is determined in two steps:

1. Determining or selecting the cooler size
2. Determining the actual pressure loss

t_{OE} [°C]	Inlet oil temperature
t_{LE} [°C]	Inlet air temperature
ETD [K]	Temperature differential: $ETD = t_{OE} - t_{LE}$
P_{spez} [kW / K]	specific cooling performance (see performance curves): $P_{spez} = P / ETD$
P [kW]	Cooling performance in kW
Q [l/min]	Oil flow rate
C_{Oil} [kJ/kgK]	Specific heat capacity of the oil (approx. 2.0 kJ / kgK)
ζ [kg/dm ³]	Gravity of oil ≈ 0.9 kg/dm ³

Calculation example

Assumptions:

Tank capacity (V) approx. 200 L

Start up temperature of oil (T_1) 15 °C (≈ 288 K)

Oil heats up in approx.

$t = 25$ min. (1500 s) to (T_2) 45 °C (≈ 318 K)

Required oil temperature (t_{OE}) 60 °C

Inlet air temperature (t_{LE}) 30 °C

Calculation

1. Calculating P from the tank warming

$$P = \frac{V \cdot \zeta \cdot c_{Oil} (T_2 - T_1)}{t} = \frac{200 \text{ l} \cdot 0.9 \frac{\text{kg}}{\text{l}} \cdot 2 \frac{\text{kJ}}{\text{kg} \cdot \text{K}} \cdot (318 \text{ K} - 288 \text{ K})}{1500 \text{ s}} = 7.2 \text{ kW}$$

2. $ETD = t_{OE} - t_{LE} = 60 \text{ °C} - 30 \text{ °C} = 30 \text{ K}$

3. Determining the cooler size: $P_{spez} = P / ETD = 7.2 \text{ kW} / 30 \text{ K} = 0.24 \text{ kW/K}$

4. In the graph, select a cooler at 80 l/min with $P_{spez} 0.24 \text{ kW/K}$. There are two options: BLK 2.2 or the larger but quieter BLK 3.4

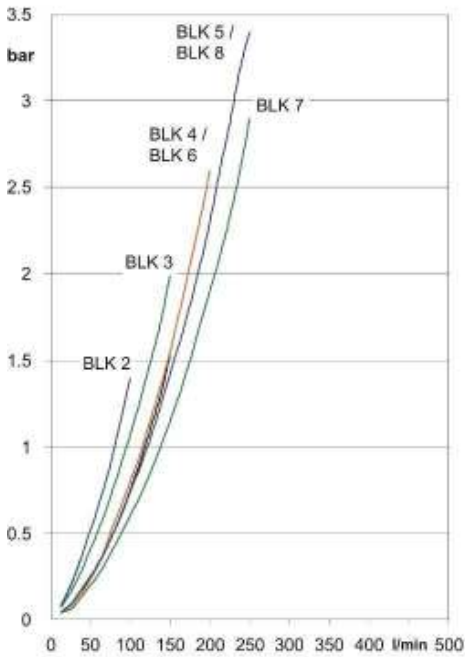
Pressure loss curves determined with an average viscosity of 30 cSt

Attention: If the coolers are used in open air or the oil has even higher viscosity the installation of by-pass valves may be necessary. Please check the section “functions schemes”.

Temperature/viscosity table

Type of oil	at 50 °C	at 60 °C	at 70 °C
VG 16	9.4	5.6	3.3 cSt
VG 22	15	11	8 cSt
VG 32	21	15	11 cSt
VG 46	29	20	14 cSt
VG 68	43	29	20 cSt
VG 120	68	44	31 cSt
VG 220	126	77	51 cSt
VG 320	180	108	69 cSt

Correction k(visk)

Viscosity (cSt)	K(visk)	Viscosity (cSt)	K(visk)
10	0.6	60	1.6
20	0.8	80	2.1
30	1.0	100	2.7
40	1.2	150	4.2
50	1.4		

Determining the actual pressure loss

1. Determine Δp from the pressure loss graph for oil flow rate Q and the selected cooler size.
2. Determine the viscosity from the type of oil and temperature.
3. Determine the correction factor k(visk) and multiply by Δp from step 1.

Performance curves

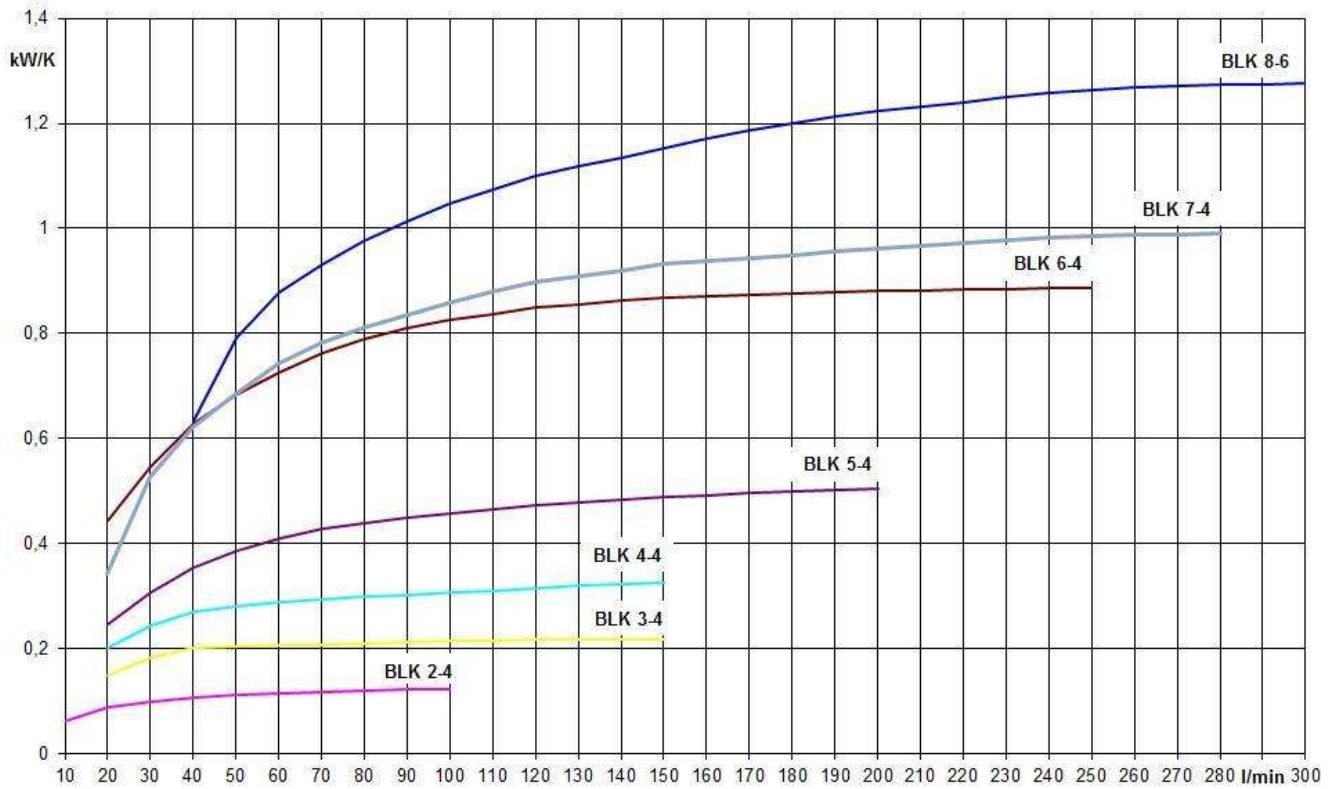

Dimensions

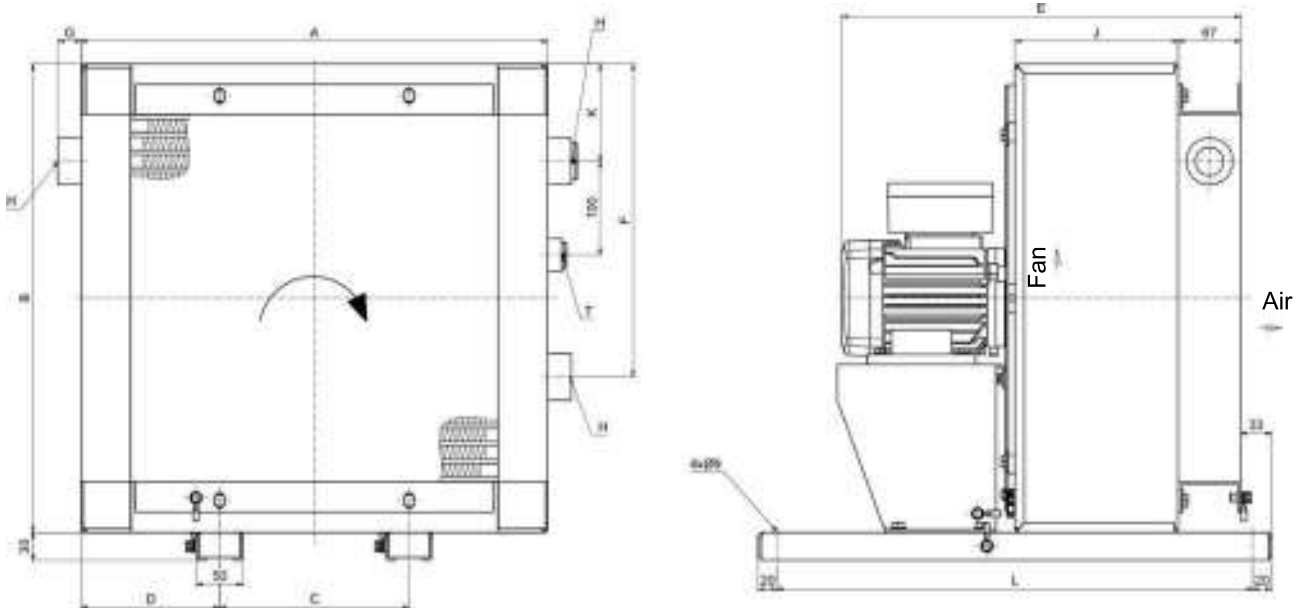

T Connection G 1/2 for temperature switch

Type	A	B	C	D	E	F	G	H	J	K	L
BLK 2.4	370	370	203	83.5	378	-	25	2x G1	125	106	510
BLK 3.4	440	440	203	118.5	440	230	25	3x G1	150	105	510
BLK 4.4	500	500	203	148.5	465	230	25	3x G1	175	104	510
BLK 5.4	580	580	356	112	523	305	23.5	3x G1	200	100	510
BLK 6.4	700	700	356	172	633	410	9.5	3x G1 1/4	225	110	510
BLK 7.4	700	840	356	172	658	590	9.5	3x G1 1/4	250	91	510
BLK 8.6	870	870	508	181	693	585	11	3x G1 1/4	275	101.5	610

Functional diagram

Standard Version BLK 2

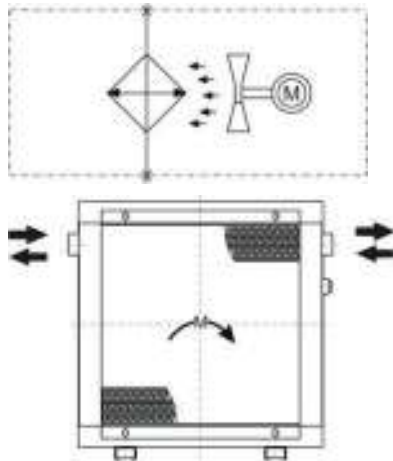

Direction of flow left to right or vice versa.

Standard Version BLK 3 to BLK 8

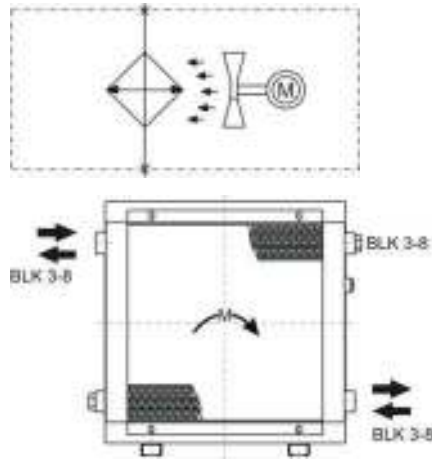

Direction of flow top left to bottom right or the exact opposite. The oil outlet is always on the opposite side. The second connection must be closed.

Internal bypass IB/ITB (BLK 3-8)

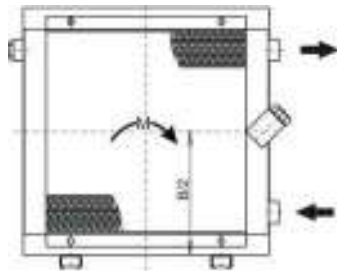

The oil inlet and outlet are always on the same side. Connections on the opposite side must be closed.

External bypass AB/ATB (BLK 2-8)

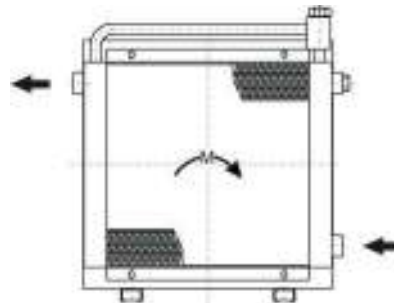

Oil inlet always at the bottom. Other connections must be closed. Oil outlet always on the opposite side.

With bypass valve

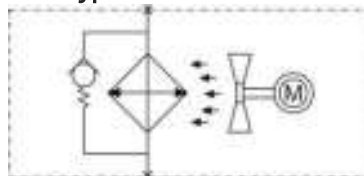

With temperature-dependent bypass valve

